

# SOLEAL NEXT

THE UNIVERSAL WINDOW



Heathervale House

Thomson Snell & Passmore



TECHNAL®

Architect: Morton Scarr  
Photographer: John Kees Photography

By  Hydro





# SOLEAL NEXT

## / THE UNIVERSAL WINDOW

### WINDOW BEYOND LIMITS FOR THE ARCHITECTURAL CREATIVITY

#### MORE POSSIBILITIES

The SOLEAL Next window was created with a view to offering architects and consultants an extensive range of solutions, giving them as much creative freedom as possible when designing a building.

##### More applications

SOLEAL Next casement is available in Visible and Minimal design, open-in and open-out to adapt to all types of architectures. There are multiple applications: 1 and 2-vents windows and patio windows, continuous horizontal windows, integrated or overlapping assemblies, fixed-light frames, fanlight and/or side fixed lights, horizontal and vertical pivot, and Italian-style. Most of these applications are available in 65 mm and 75 mm.

Residential doors are also offered with low threshold for reduced mobility access. The installation and cladding environments are the same as for SOLEAL Next doors and sliders.

##### More comfort

SOLEAL Next offers effective thermal, acoustic and weather tightness performances, complying with most international regulatory requirements. Ventilation and micro ventilation solutions are available as optional features.

##### More design

SOLEAL Next combines aesthetic design with a large choice of colours and accessories, as well as concealed elements, bringing elegance and modernity to new or renovated building projects.

#### LESS IMPACT

Using the UN Sustainability Goals as our compass, we aim to reduce by half our CO<sub>2</sub> emissions by 2025 and commit to contribute to quality education and capacity building for 500,000 people in our communities and for business partners from 2018 until the end of 2030.

##### Less CO<sub>2</sub> footprint

Using Hydro CIRCAL®, an alloy made with a minimum of 75% recycled end-of-life aluminium (post-consumer scrap), allows tons of scrap that would otherwise become solid waste to be reintroduced into the system. SOLEAL Next's thermal break elements are made from recycled material.

##### More recyclable

SOLEAL Next is under certification to obtain Cradle to Cradle® label. The specific characteristics contribute to constructing sustainable buildings that are eligible to be awarded to the main environmental certifications.

# SOLEAL NEXT 65 & 75

/ MORE POSSIBILITIES. LESS IMPACT.



# KEY FEATURES & INNOVATIONS

## MORE DESIGN & AESTHETICS

- Wide choice of Minimal and Visible vents and frames design
- Concealed hardware
- Concealed handle and drainage
- EXCLUSIVE® handle collection
- EXCLUSIVE® colour range

## LARGE DIMENSIONS

- Module: 65 and 75 mm
- Height: up to 3 meters
- Glazing thickness: up to 69 mm
- Infill weight: up to 160 kg

## MORE APPLICATIONS

- Numerous opening possibilities
- Façade and other ranges integration
- Composite assemblies
- Horizontal and vertical pivot frame
- Residential door
- Patio window
- Juliet balcony
- Motorisation available
- Magnetic window contact
- Wireless window contact: energy harvesting without battery

## MORE SAFETY AND ACCESSIBILITY

- Burglary resistance: RC2, RC3 and PAS24
- Security glazing beads for glass pan installation from the outside, including open-out
- Magnetic window contact: certified for high-end security
- Antibacterial coating on handles on demand
- Reduced threshold for disabled: 15-20 mm

## MORE PERFORMANCES

- Thermal:  $U_w$  up to 0.78 W/m<sup>2</sup>K
- Air permeability: Class 4
- Watertightness:
  - up to 1500 Pa for open-in
  - up to 1800 Pa for open-out
- Wind pressure resistance: Class 5
- Acoustic performance:  $R_w$  up to 48 dB

## MORE SUSTAINABILITY

- SOLEAL Next is made in Hydro CIRCAL®, aluminium made with a minimum of 75% recycled end-of-life aluminium.
- PVC-free components
- Cradle to Cradle®: under certification
- Dynamic EPD available on TechDesign
- 75% recycled and 95% recyclable

## SOFTWARE

- Available in TechDesign
- BIM: available in Tech3D, Archicad and REVIT
- TechAcoustic

# SOLEAL NEXT

/ A MODULAR SOLUTION

## MINIMAL

The fine lines of the Minimal vent contribute to creating elegant and minimalistic architecture.

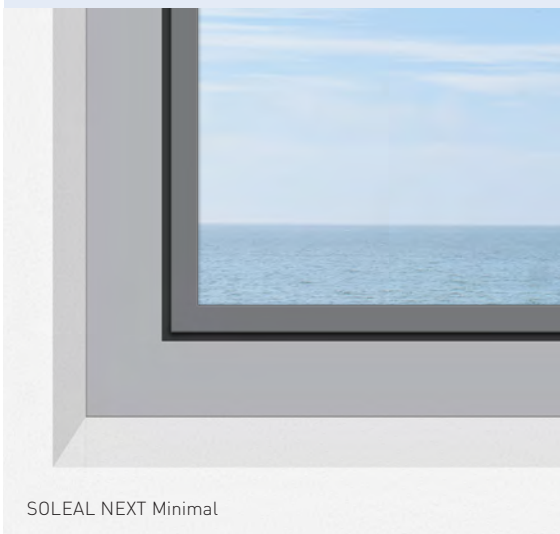
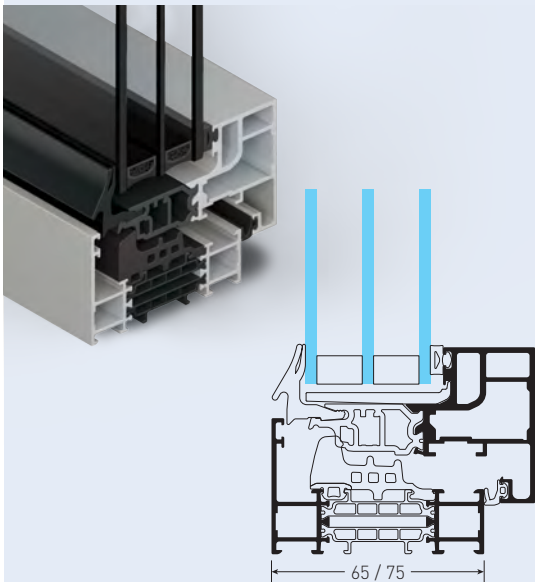

SOLEAL NEXT Minimal

## MINIMAL CLIP-ON TRIM

The clip-on-trim adds modernity to the joinery and discreetly highlights the presence of the opening vent.

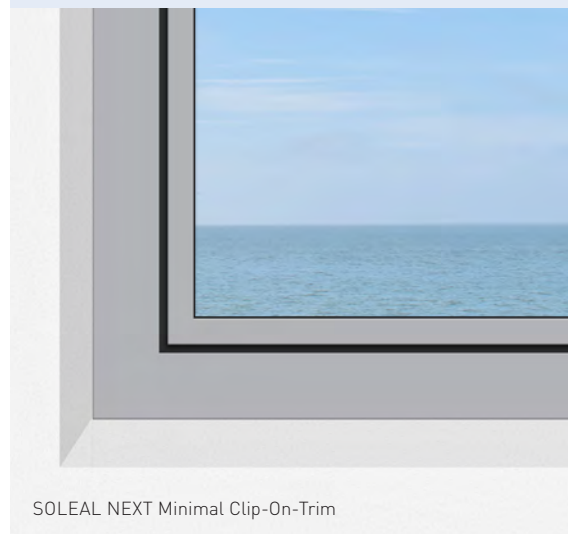
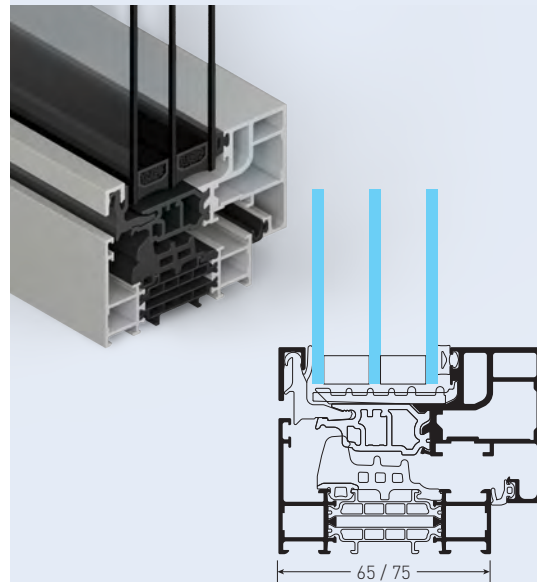

SOLEAL NEXT Minimal Clip-On-Trim

## VISIBLE OPEN-IN

The visible structure is balanced between the fixed frame and the opening vent, providing an additional aesthetic touch to the window.

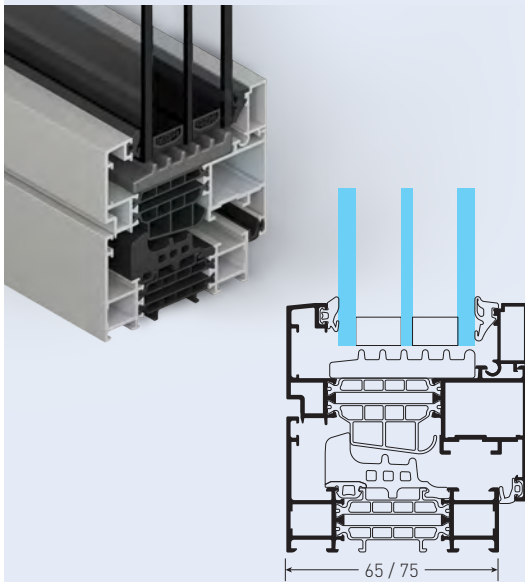

SOLEAL NEXT Visible Open-In

## VISIBLE OPEN-OUT

Not only are there several designs of visible vents, it's also available for outward opening, giving a wide choice of possibilities.

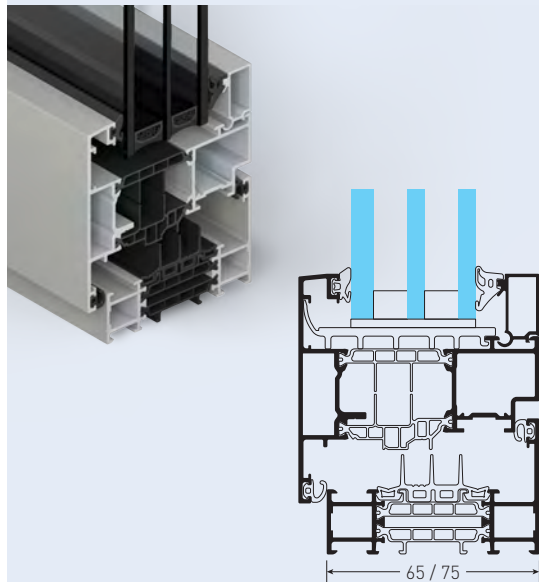

SOLEAL NEXT Visible Open-Out

# SOLEAL NEXT

/ A MODULAR SOLUTION

## MINIMAL

The fine lines of the Minimal vent contribute to creating elegant and minimalistic architecture.

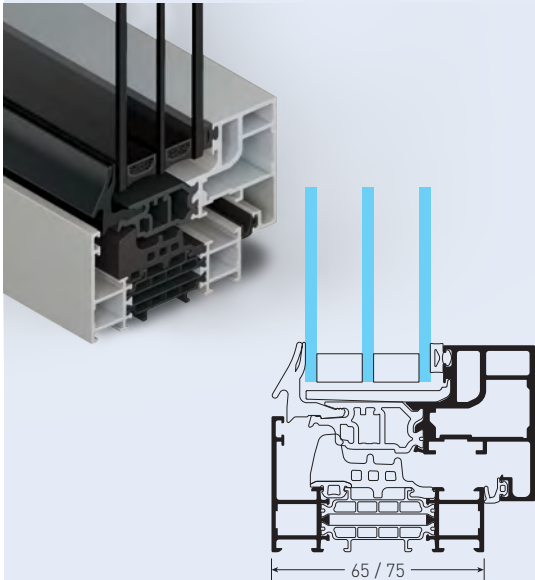

SOLEAL NEXT Minimal

## VISIBLE OPEN-IN SQUARE

The visible structure is balanced between the fixed frame and the opening vent, providing an additional aesthetical touch to the window.

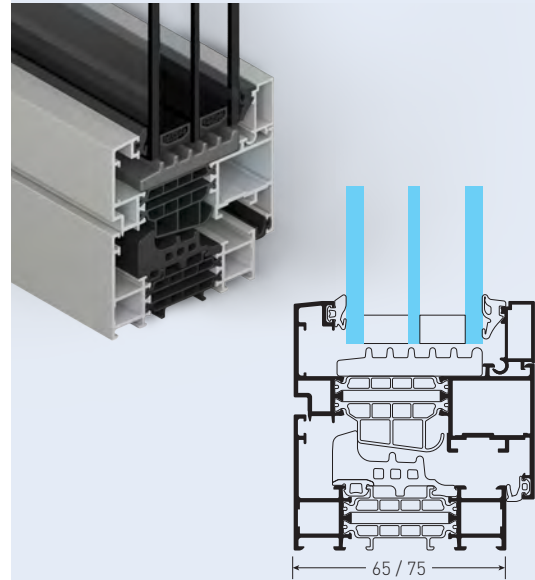

SOLEAL NEXT Visible Open-In Square



## VISIBLE OPEN-IN FLUSH

The visible structure is balanced between the fixed frame and the opening vent, providing an additional aesthetic touch to the window.

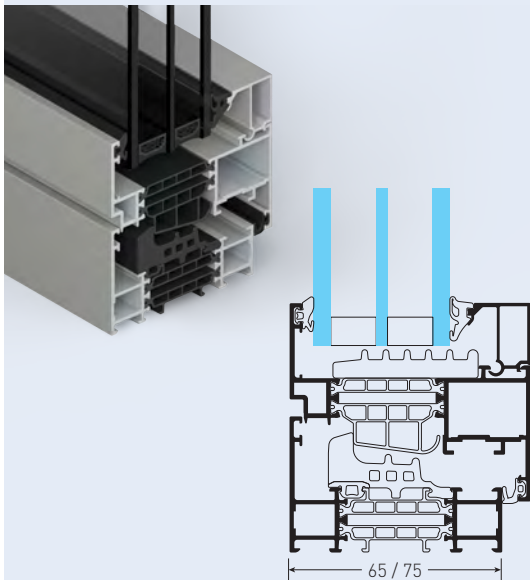

SOLEAL NEXT Visible Open-In Flush

## VISIBLE OPEN-OUT

Not only are there several designs of visible vents, it's also available for outward opening, giving a wide choice of possibilities.

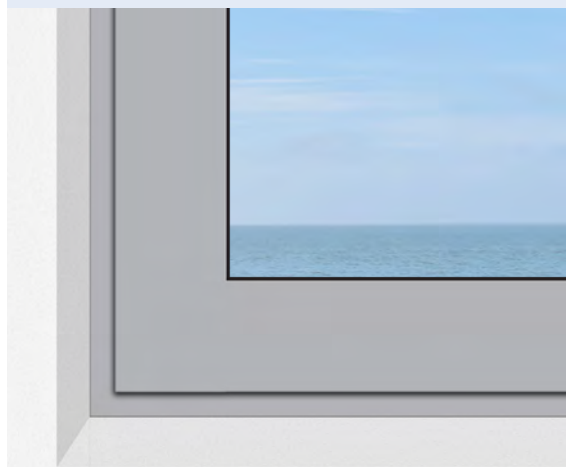
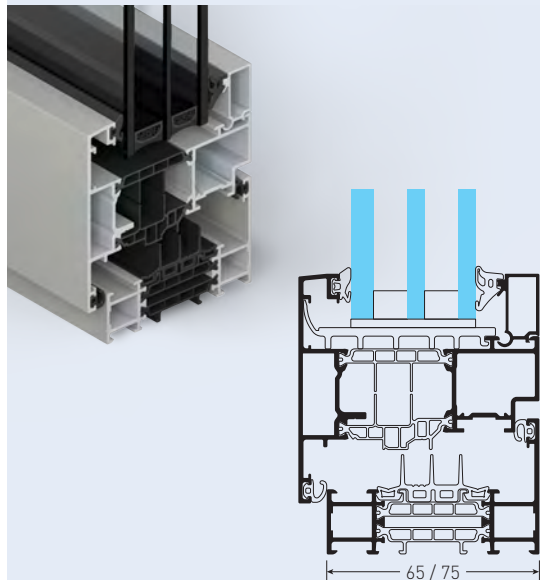

SOLEAL NEXT Visible Open-Out

# SOLEAL NEXT

## / MINIMAL

With a range of 5 different frames and 4 different vent designs, SOLEAL Next Minimal can be offered in 20 different visual aspects.

### FRAME DESIGNS

- Standard
- Step
- Slope
- Concealed drainage
- T frame with concealed drainage

### VENT DESIGNS

- Square
- Step
- Slope
- Clip on trim

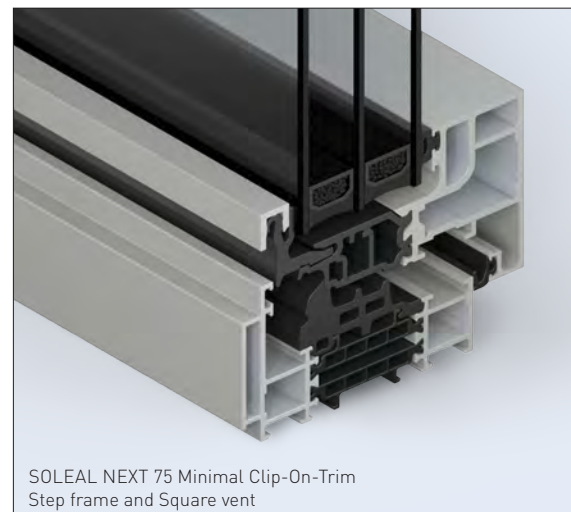
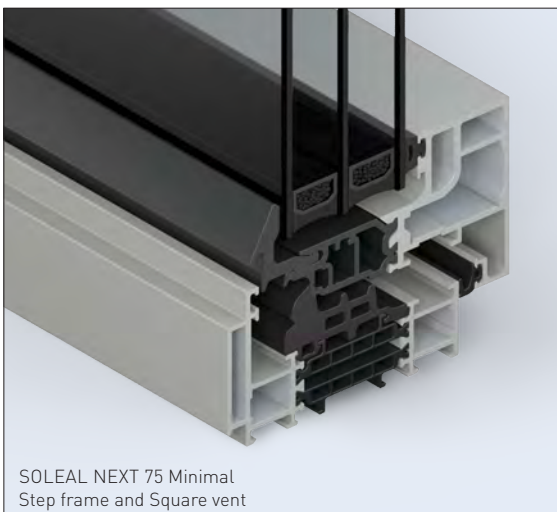
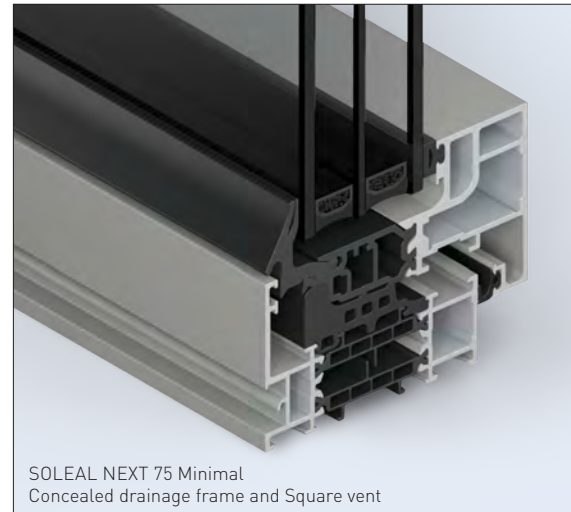
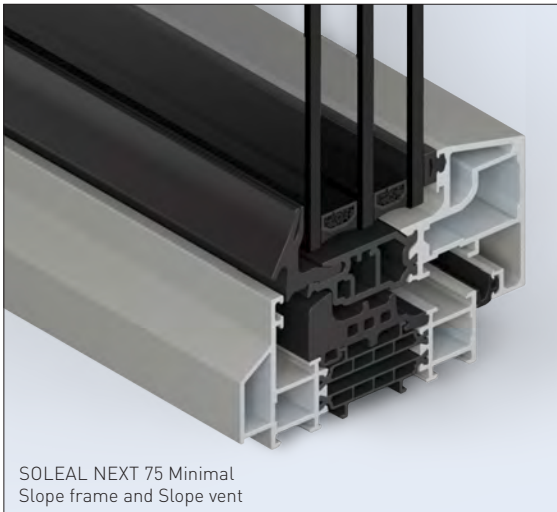

The patented minimalist opening frame with slim, subtle sightlines is perfect to reduce the visible aluminium and to increase the amount of glazing.

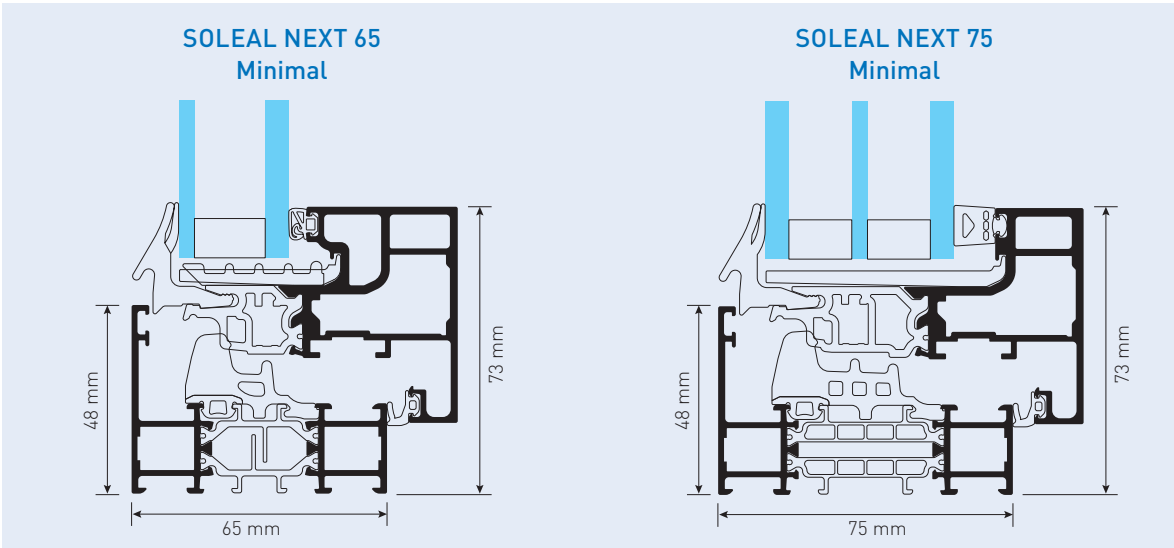

# SOLEAL NEXT

## / VISIBLE OPEN-IN

With a range of 5 different frames and 5 different vent designs, SOLEAL Next Visible can be offered in 25 different visual aspects.

### FRAME DESIGNS

- Standard
- Step
- Slope
- Concealed drainage
- T frame with concealed drainage

### VENT DESIGNS

- Square
- Step
- Slope
- Soft
- Flush

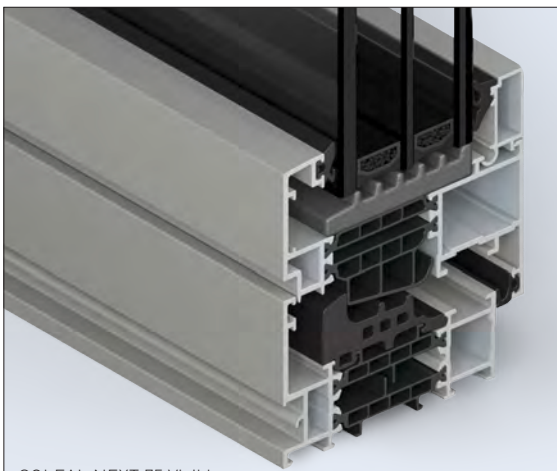

SOLEAL NEXT 75 Visible  
Concealed drainage frame and Square vent

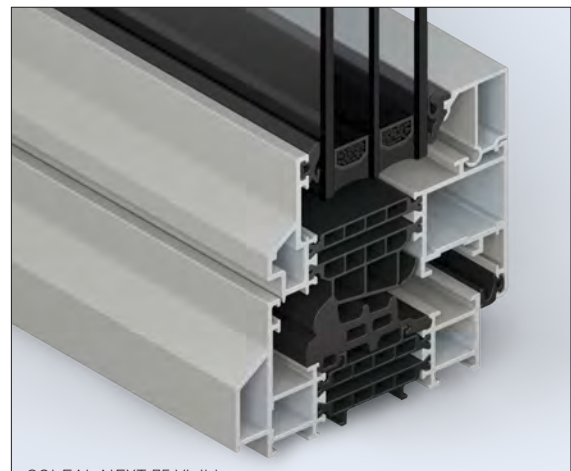

SOLEAL NEXT 75 Visible  
Slope frame and Slope vent

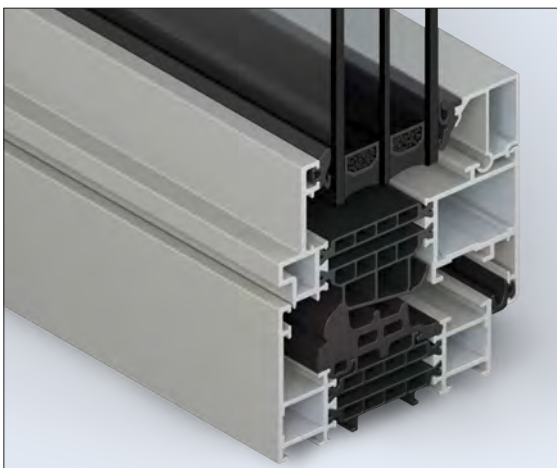

SOLEAL NEXT 75 Visible  
Standard frame and Step vent

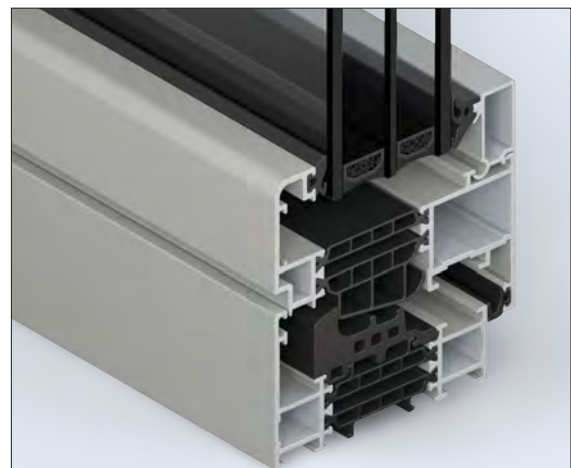

SOLEAL NEXT 75 Visible  
Standard frame and Soft vent

The stylish visible opening frame provides a contemporary, modern aesthetic.

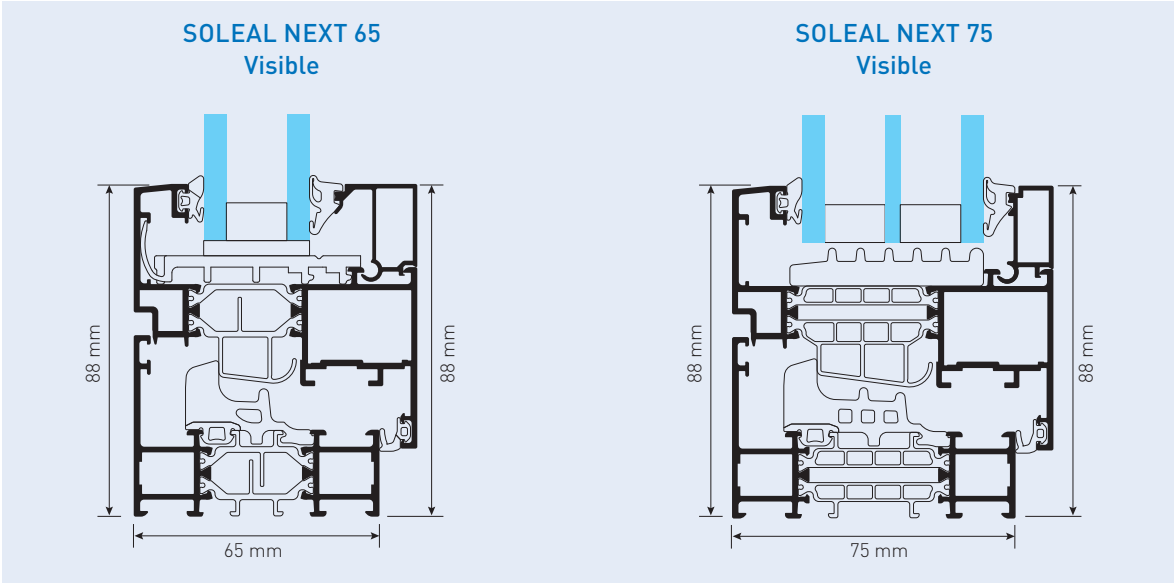

# SOLEAL NEXT

## / VISIBLE OPEN-IN

With a range of 5 different frames and 5 different vent designs, SOLEAL Next Visible can be offered in 25 different visual aspects.

### FRAME DESIGNS

- Standard
- Step
- Slope
- Concealed drainage
- T frame with concealed drainage

### VENT DESIGNS

- Square
- Step
- Slope
- Soft
- Flush



SOLEAL NEXT 75 Visible  
T-frame and Flush vent

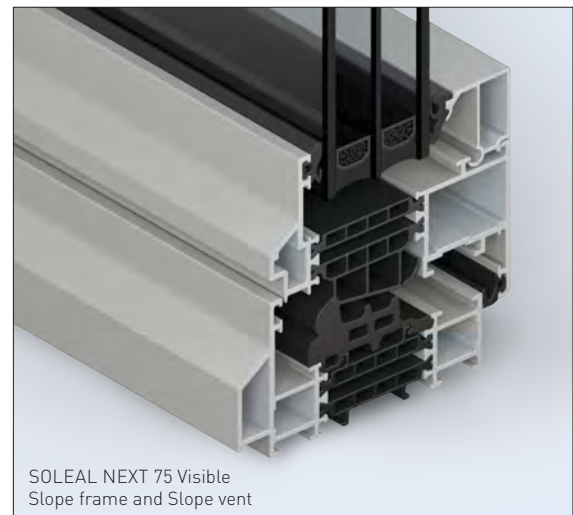

SOLEAL NEXT 75 Visible  
Slope frame and Slope vent

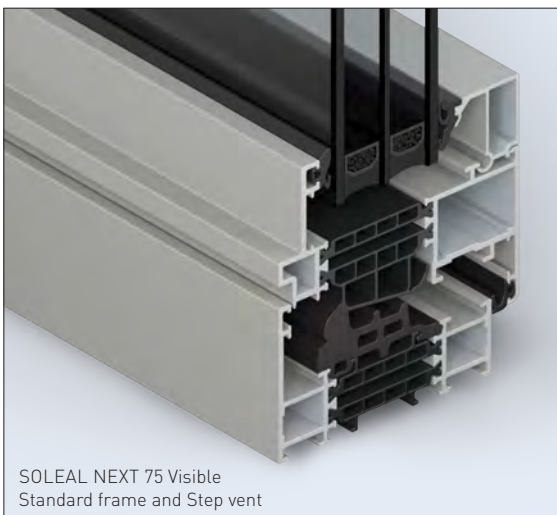

SOLEAL NEXT 75 Visible  
Standard frame and Step vent

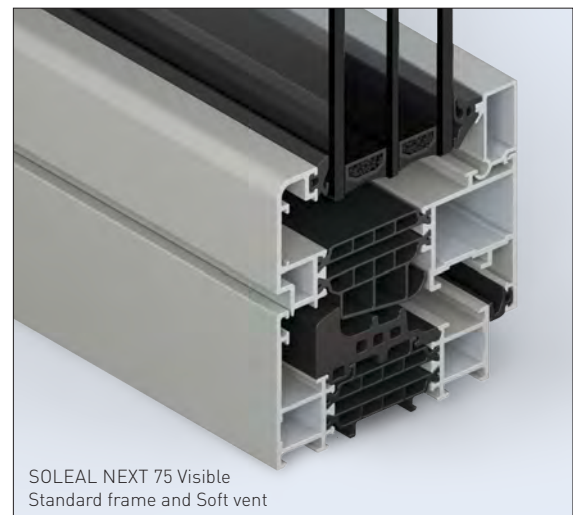

SOLEAL NEXT 75 Visible  
Standard frame and Soft vent

The stylish visible opening frame provides a contemporary, modern aesthetic.

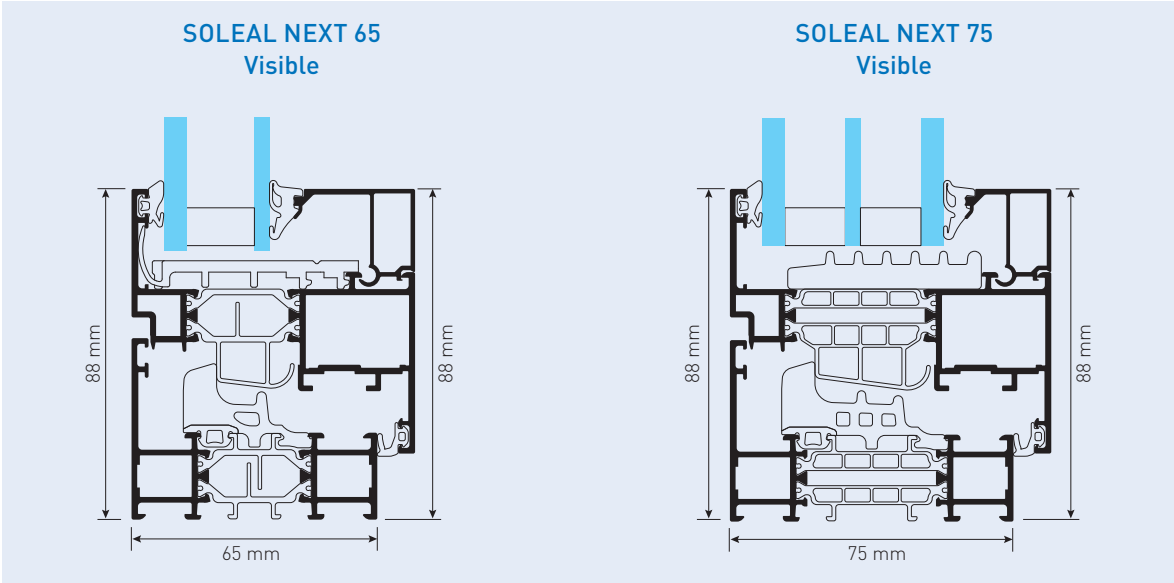

# SOLEAL NEXT

/ VISIBLE OPEN-OUT

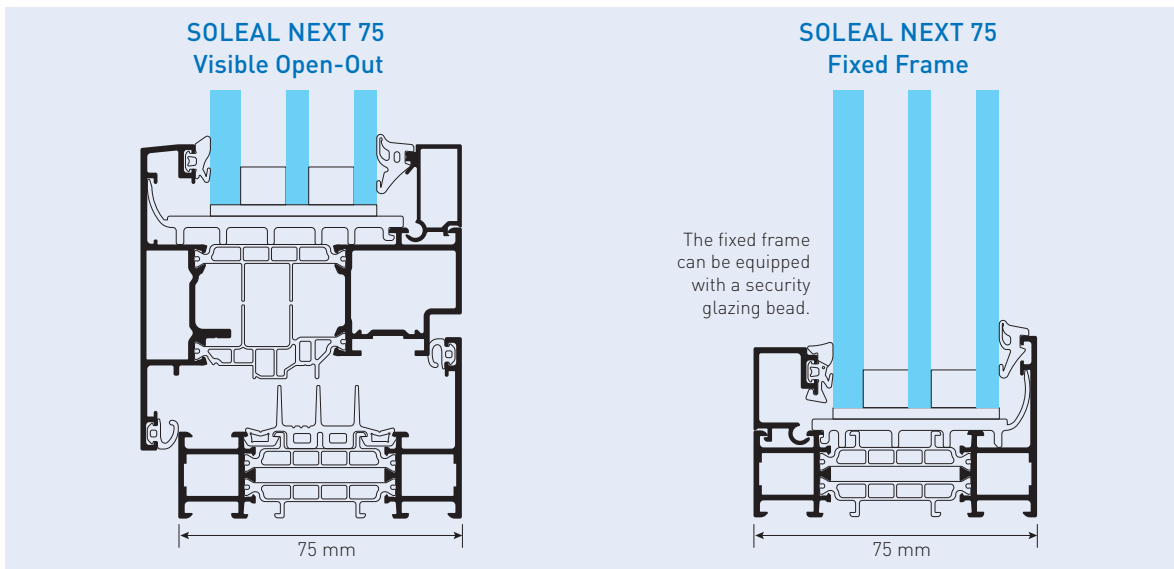

## WINDOW FEATURES

- Vent optimized for friction stay (No packer on the vent)
- Straight cut central gasket (Overlapping lips)
- Exist in single and double vent
- PAS24 available

## RESIDENTIAL DOOR FEATURES

- Door lock offer
- Door hinges tested at 200 000 cycles

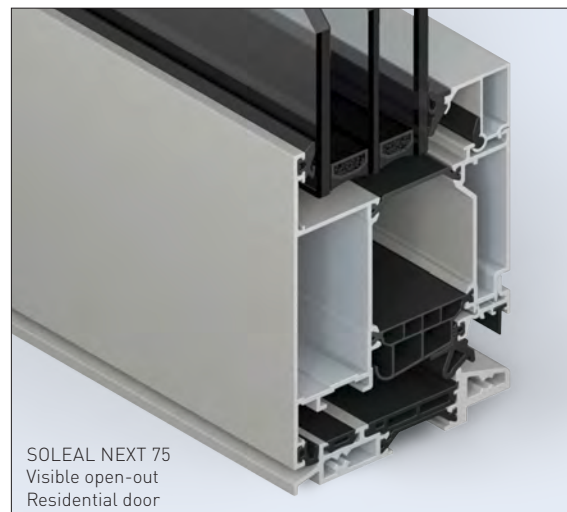
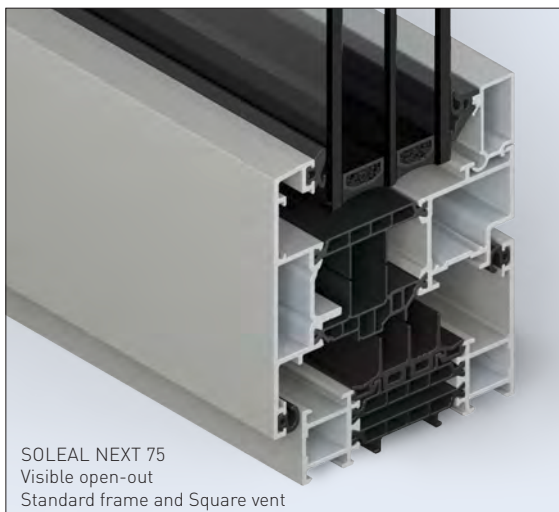





# SOLEAL NEXT

## / CONCEALED ELEMENTS AND HARDWARE

### AESTHETICS

- Invisible hinges to create a minimalistic look
- Thin hardware components, harmonious finishes
- Finishing covers tie rod and frame groove for a clean appearance

### FAST ASSEMBLY

- Frontal mounted elements
- Direct punching of the tie rod
- No groove notching on the vent
- Positioning with breakable stoppers

### SIMPLE SUPPLY

- No coated or anodized part, which reduces lead time for supply
- All components are common except for the bottom hinge, which enables stock to be built up according to weight and opening

### LARGE DIMENSIONS

- Up to 3 m height
- 160 kg per vent

### COMPREHENSIVE SOLUTION

- Bottom hinges adapted to the weight of the glazing and the type of project:

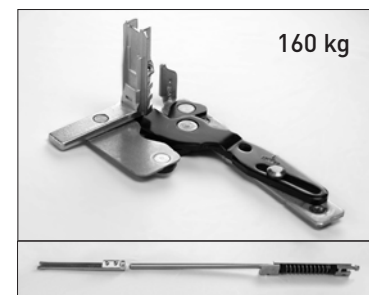
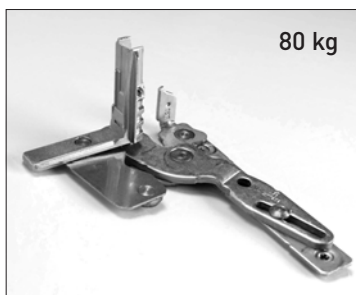

## CONCEALED HANDLES

The window handle is hidden in the vent, adding to the harmonious appearance of the window. This innovative design idea was awarded prizes from the international expert juries of the iF DESIGN AWARD, the Red Dot Design Award. This feature is proposed on the Minimal vent.



## CONCEALED DRAINAGE

Concealed, our drainage is strategically placed on the casement frame to drain water out while preventing the air from coming inside.

If visible, our minimalistic drainage cap features standard colour, or lacquered in order to match the tint of the window.

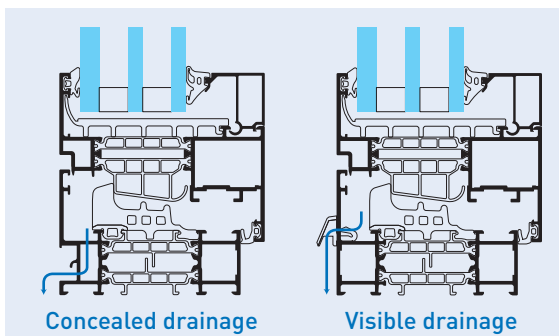

Concealed drainage versus traditional drainage through the frame profile and drainage caps



**Architect:** Elding Oscarsson Architects  
**Photographer:** Erik Wik

# SOLEAL NEXT

/ MORE AESTHETIC FEATURES

## 2 VENTS MULLION SOLUTIONS

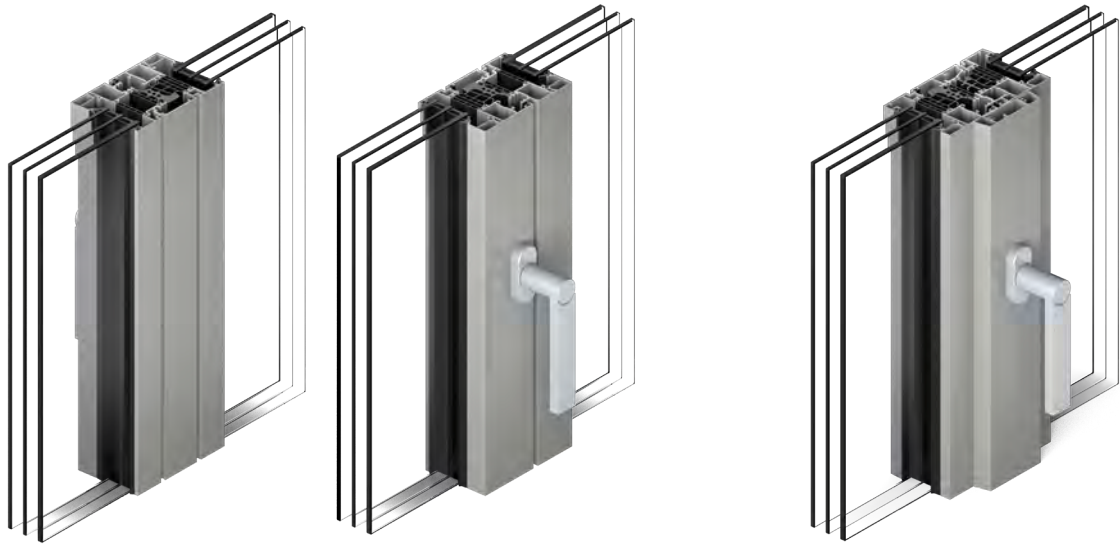

### REDUCED EXTERNAL SIGHTLINE

- 146 mm for Visible vent with central mullion
- 126 mm for Visible vent with reduced central mullion
- 66 mm for Minimal vent

### CENTERED HANDLE

- Contributes to an harmonious internal design
- Available in Minimal and Visible vent

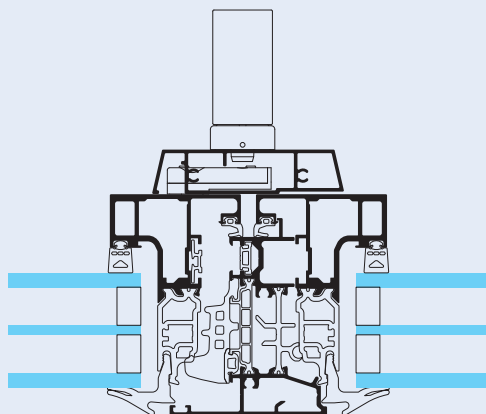

SOLEAL NEXT Minimal  
centered handle

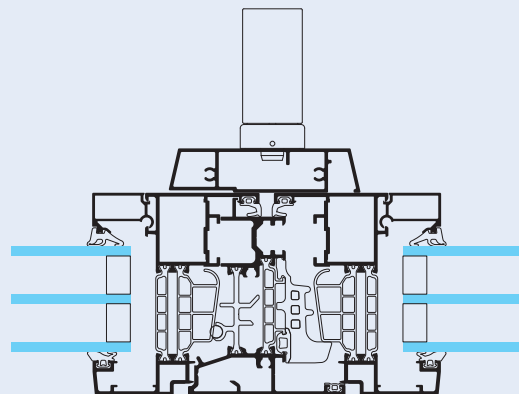

SOLEAL NEXT Visible  
centered handle

COMPOSITE FRAME WITH OPEN-IN VENT

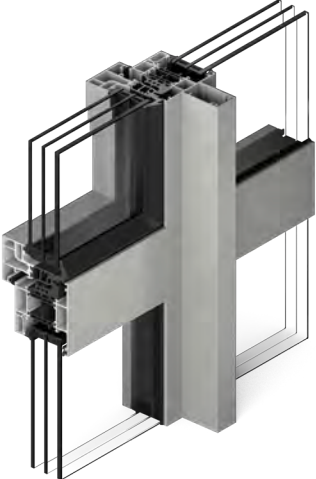

Minimal

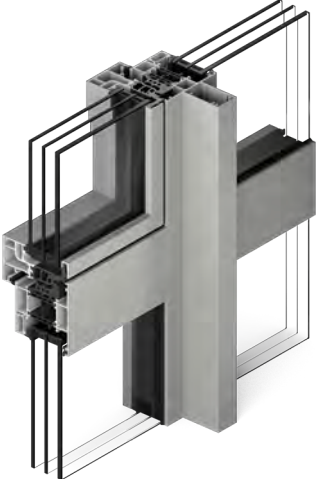

Minimal Clip-On-Trim

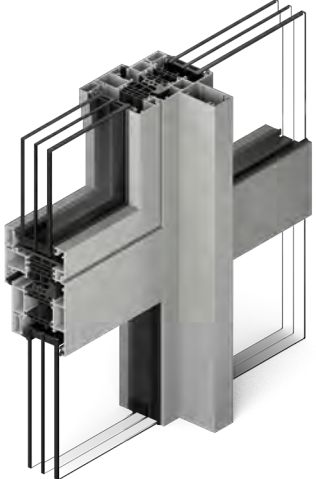

Visible Open-In



**Architect:** archi Cuanctics Creatives – Diego Soroa / LKS Ingeniería – Mikel Txintxurreta, Igoné Asuay Patxi Larzogitia  
**Photographer:** Wenzel

# SOLEAL NEXT

/ MORE AESTHETIC FEATURES

## 2 VENTS MULLION SOLUTIONS

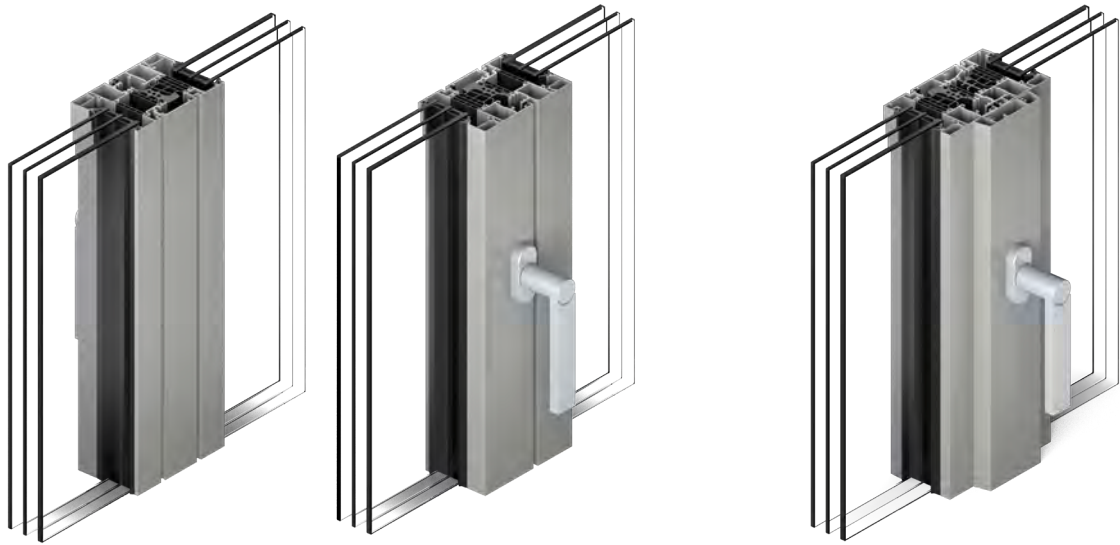

### REDUCED EXTERNAL SIGHTLINE

- 146 mm for Visible vent with central mullion
- 126 mm for Visible vent with reduced central mullion
- 66 mm for Minimal vent

### CENTERED HANDLE

- Contributes to an harmonious internal design
- Available in Minimal and Visible vent

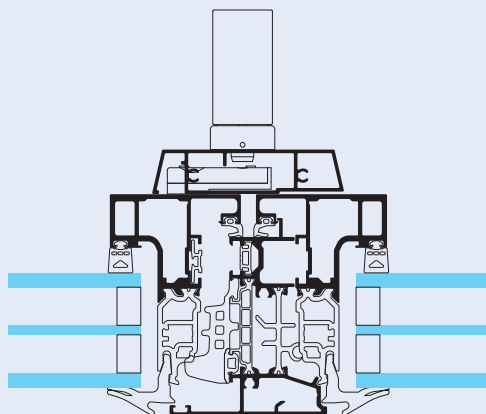

SOLEAL NEXT Minimal  
centered handle

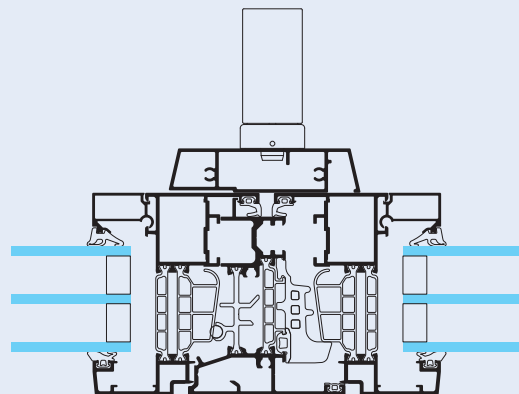

SOLEAL NEXT Visible  
centered handle

COMPOSITE FRAME WITH OPEN-IN VENT

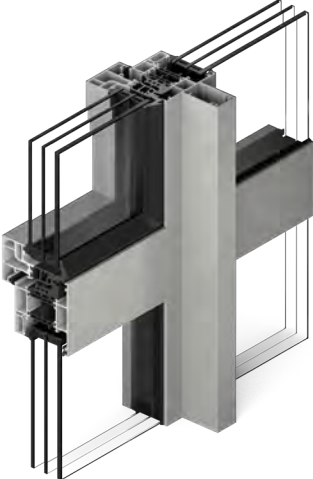

Minimal

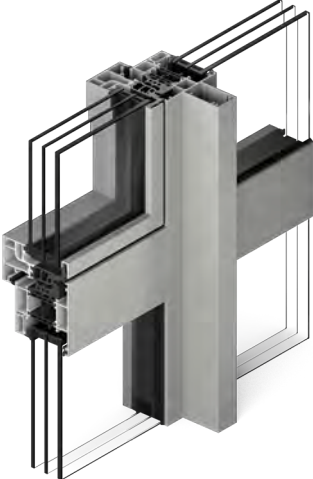

Minimal Clip-On-Trim

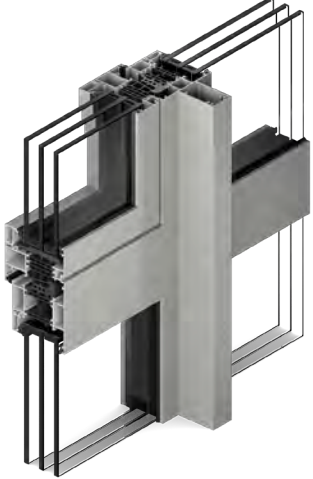

Visible Open-In Flush



**Architect:** archi Cuanctics Creatives – Diego Soroa / LKS Ingeniería – Mikel Txintxurreta, Igoné Asuay Patxi Larzogitia  
**Photographer:** Wenzel

# SOLEAL NEXT

## / EXCLUSIVE® HANDLES COLLECTION

The discreet but effective design approach for our new EXCLUSIVE® range - SELECTION, TEMPTATION & PASSION - aims to allow users to customise their handles, creating a sophisticated but timeless and functional visual signature on SOLEAL Next windows. Our handles offer a wide choice of colours, noble materials and clean lines.



### / SELECTION

True to TECHNAL's practical approach to design, this range of handles draws attention with its understated and elegant lines. A strong visual identity with simple and graphic geometric shapes, round or square, with an ergonomic design to the touch that modernises the current offer. Proven quality, with anodised or coated finishes for each handle, not to mention the new black anodised finish that adds an extra level of sophistication.



### / TEMPTATION

This range builds on TECHNAL's expertise, taking its extruded aluminium design to new levels of high quality and clean lines. All the elements come in a mix of finishes, textures and colours and can be combined to get unique and personalised colour options. All this designed to achieve a unique visual sensation and a magnificent experience to the touch.



### / PASSION

Taking design to new heights, the passion range is a new expression in luxury fittings, with exclusive mixes of finishes and materials aimed at pleasing even the most demanding users. Making use of simple geometric shapes, this collection works as the perfect complement to a wide range of architectural aesthetics.





ROUND AND  
SQUARED HANDLES  
WITH STANDARD ROSETTES



HANDLES  
WITH  
LOCKS

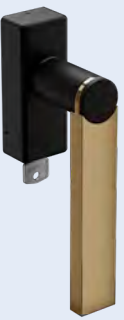

# SOLEAL NEXT

/ MORE COLOURS



## TECHNAL RELEASES THE COLOURS FOR A LIVING ARCHITECTURE

Ever faithful to its creative and architectural logic, TECHNAL has enriched its colour range with different collections. To highlight the EXCLUSIVE COLLECTION.

At first glance, it's the material that speaks. This voice comes from the colours themselves, which are sometimes concrete and solid and sometimes light and volatile.

This choice of material is also enhanced by looks or finishes: the classic / satin / gloss duo is joined by textured, matt, metallised, spangled or even iridescent finishes.

This visual and tactile experience is primarily an echo of noble and ancestral materials - the rustic character of the earth, the raw harshness of adobe, the grain of stone - all expressed through colour.

It's also the imprint of innovation which mixes the ephemeral play of light and the changing nature of pigment in colour and recreates a new materiality that has never been seen before.

## FINISHES AND COLOURS

A wide range of finishes and colours is available to meet individual project requirements, enhancing existing buildings and offering architects and designers greater design freedom:

- Natural anodised in accordance with "QUALANOD" instructions. EN 23731:2001.
- Polyester coating finishes in a wide range of colours in accordance with "QUALICOAT" and "QUALIMARINE" instructions.
- SOLEAL NEXT is also available in lacquered finishes with the colour range EXCLUSIVE® for a stylish and contemporary look.

## EXCLUSIVE / CLASSIC COLLECTION

The Classic Collection is made up a unique selection of aluminium finishes offering different material effects: grained, frosted and patina. Every face of metal is explored to combine colour, texture and light.



## EXCLUSIVE / DOWNTOWN COLLECTION

Developed in collaboration with architects, this collection is made up of eight 100% exclusive colours which enhance the aluminium. The combination of materials and light effects highlight the simplicity and elegance of the subtle colours which are reminiscent of natural materials.

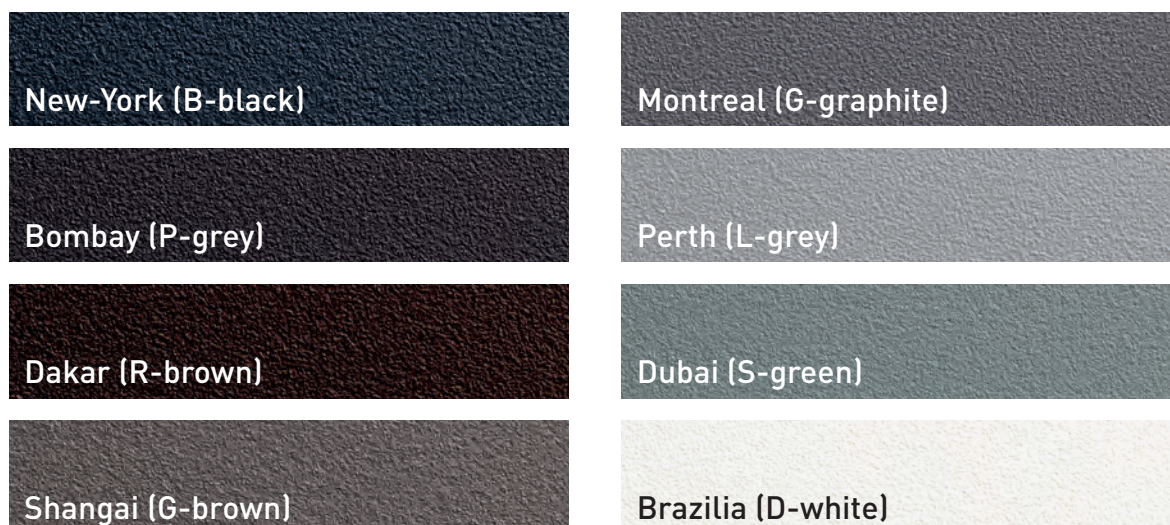



SOLEAL NEXT 75  
Minimal Open-In



SOLEAL NEXT 75  
Visible Open-Out



# APPLICATIONS 75 MM MODULE

## OPEN-IN



Fixed frame

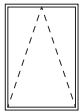

Bottom-hung

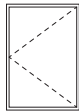

1 vent

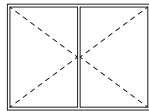

2 vents



Turn/tilt or  
tilt/turn 1 vent

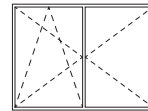

Turn/tilt or tilt/turn  
2 vents

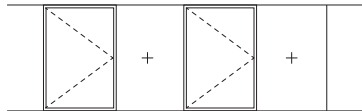

Ribbon window

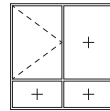

Fixed composite  
open-in window

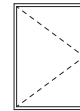

Fireman access

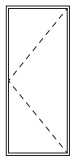

Residential door with  
threshold 1 vent

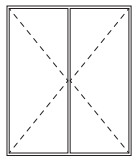

Residential door with  
threshold 2 vents

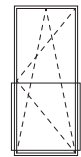

Juliet balcony

## OPEN-OUT

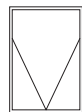

Top-hung

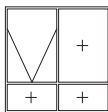

Fixed composite  
top-hung

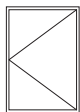

Side hung  
1 vent

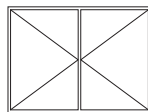

Side hung  
2 vents

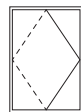

Pivot  
H + V

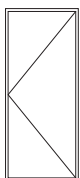

Residential door  
with threshold  
1 vent

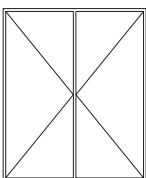

Residential door  
with threshold  
2 vents



SOLEAL NEXT 65  
Minimal Open-In



SOLEAL NEXT 65  
Visible Open-In



# APPLICATIONS 65 MM MODULE

## OPEN-IN



Fixed frame

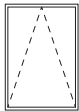

Bottom-hung

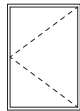

1 vent

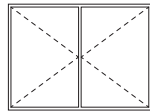

2 vents



Turn/tilt or  
tilt/turn 1 vent

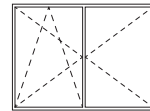

Turn/tilt or tilt/turn  
2 vents

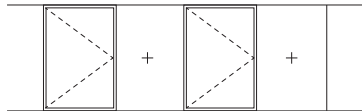

Ribbon window

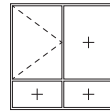

Fixed composite  
open-in window

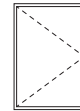

Fireman access

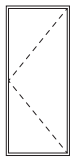

Residential door with  
threshold 1 vent

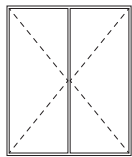

Residential door with  
threshold 2 vents

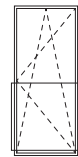

Juliet balcony

## OPEN-OUT\*

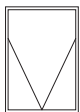

Top-hung

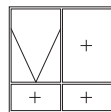

Fixed composite  
top-hung

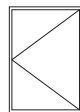

Side hung  
1 vent

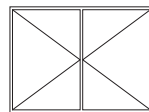

Side hung  
2 vents

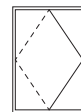

Pivot  
H + V

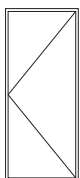

Residential door  
with threshold  
1 vent

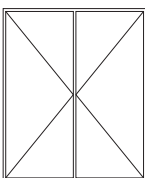

Residential door  
with threshold  
2 vents

\* available in 2023.

# SOLEAL NEXT

/ MORE APPLICATIONS

## CURTAIN WALL INTEGRATION

All SOLEAL Next vents can be integrated in TENTAL 50 and 60 curtain wall.

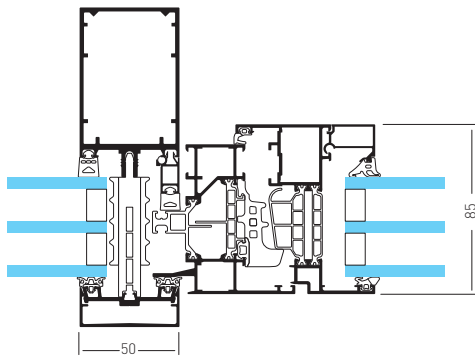

SOLEAL NEXT 75  
Visible Flush integrated in TENTAL 50

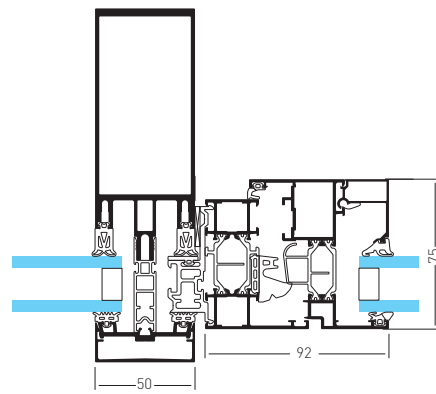

SOLEAL NEXT 65  
Visible Flush integrated in TENTAL 50

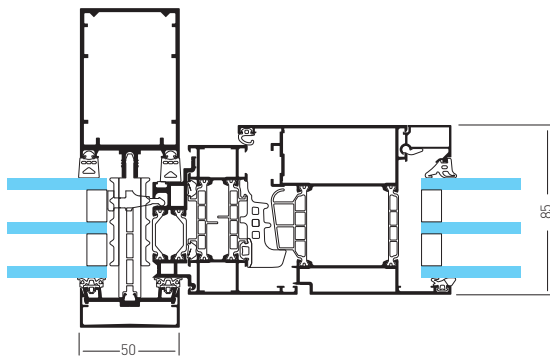

SOLEAL Next 75  
Visible Residential Door integrated in TENTAL 50

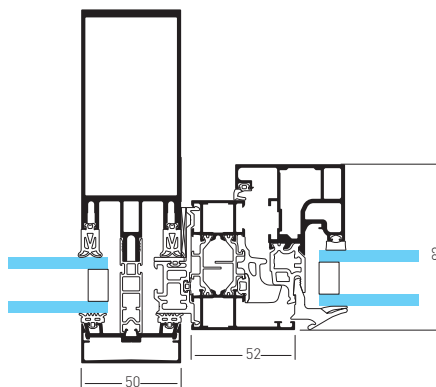

SOLEAL Next 65  
Minimal integrated in TENTAL 50



## COUPLING

A range of couplers exist in 65mm and 75mm modules to fit with other product ranges from 65mm up to 180mm frame depth.

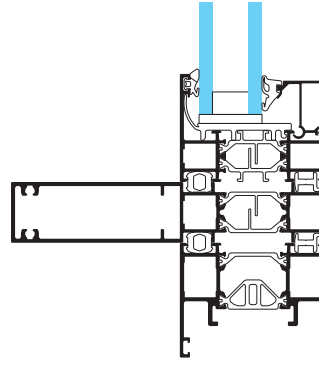
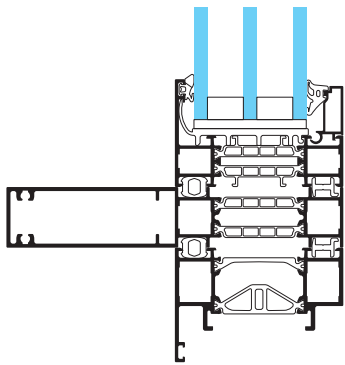

SOLEAL NEXT 75  
Reinforced add-on mullion fixe glass and door  
frame

SOLEAL NEXT 65  
Reinforced add-on mullion fixe glass and door  
frame

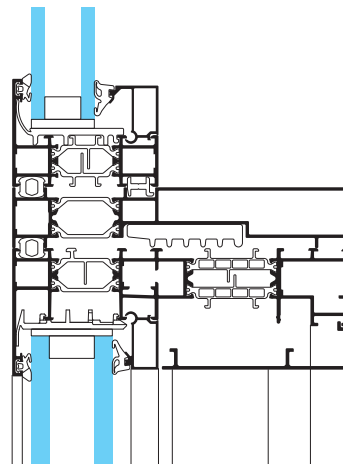
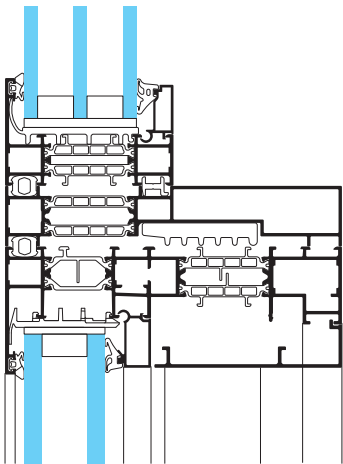

SOLEAL NEXT 75  
Add-on mullion with TIGAL pull & slide

SOLEAL NEXT 65  
Add-on mullion with TIGAL pull & slide

# SOLEAL NEXT

/ RESIDENTIAL DOOR

## 2 BOTTOM SECTION OPTIONS

- Features no threshold with drop seal
- One low threshold profile to allow easy entrance for disabled

## ENDURANCE

- Door hinges tested: 200.000 cycles

## APPLICATIONS

- Single and double residential door open-in
- Single and double residential door open-out



## / MORE ACCESSIBILITY

### THRESHOLD FOR DISABLED

- Adapted for easy access on all available applications:
  - Easy opening / closing
  - Adaptable handle height
- No functional gasket at bottom
- No front drainage like flush doors
- Sloped < 5mm
- 15 mm and 20 mm solution can be used with support profile

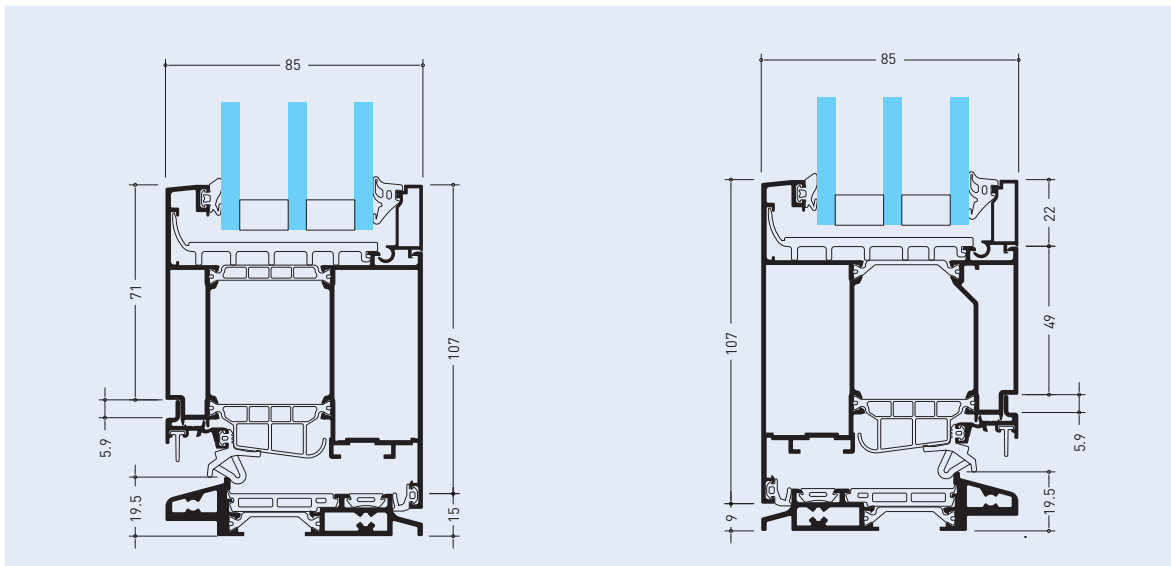
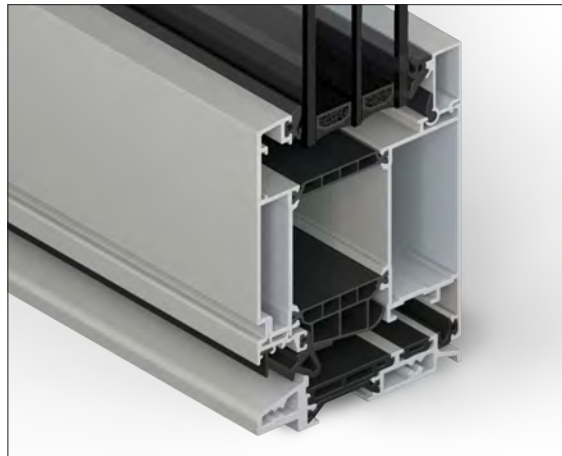

# SOLEAL NEXT

/ MORE COMFORT

## JULIET BALCONY

Integrated into the window system, the Juliet balcony is a glass balustrade which provides additional safety for peace of mind.

- Can be fixed on 65 and 75 mm module
- Glass can be installed from the inside or from outside
- Limited to 35 mm protrusion for roller shutters
- End plugs without screws visible from the outside
- 2 profiles dimensions to allow standard or XL Juliet balcony
  - Standard glazing and max dimensions: 66,4 / 1300mm - 88,4 / 1600 mm. Maximum height 1200mm
  - XL glazing and max dimensions: 1010,4 / 2300mm - 1212,4 / 2900 mm. Maximum height 1200mm

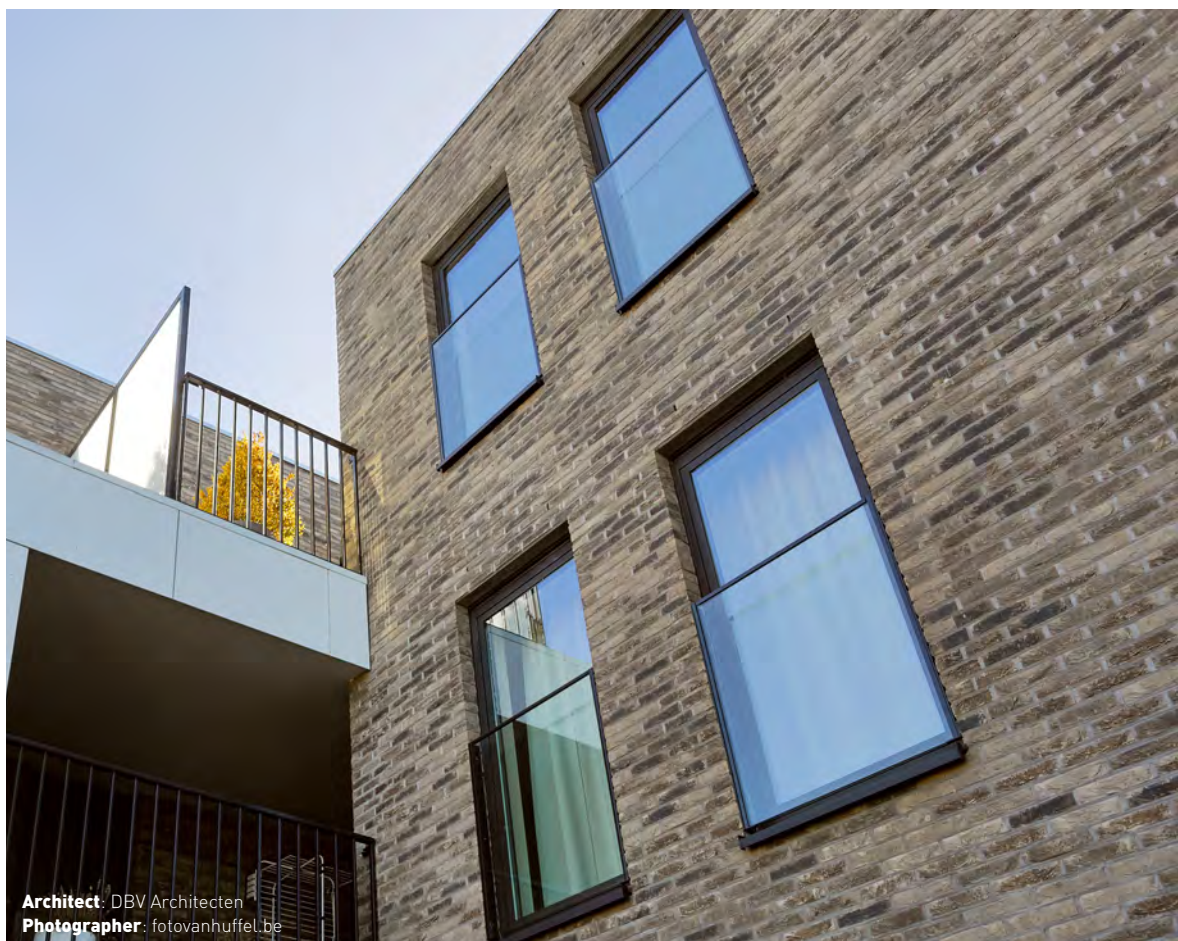

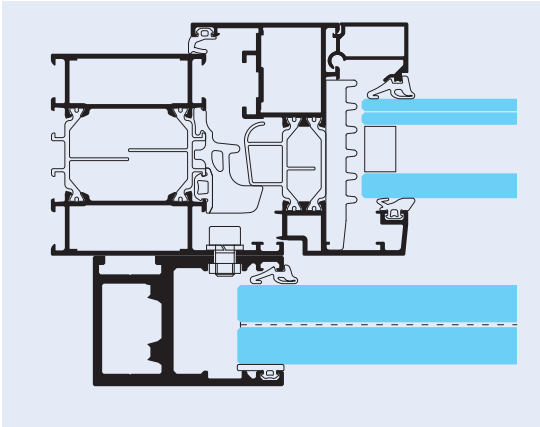

Soleal Next 65: Fixation from the inside

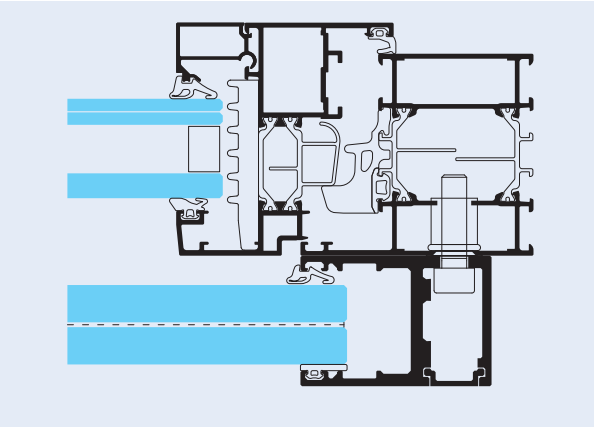

Soleal Next 65: fixation from the outside

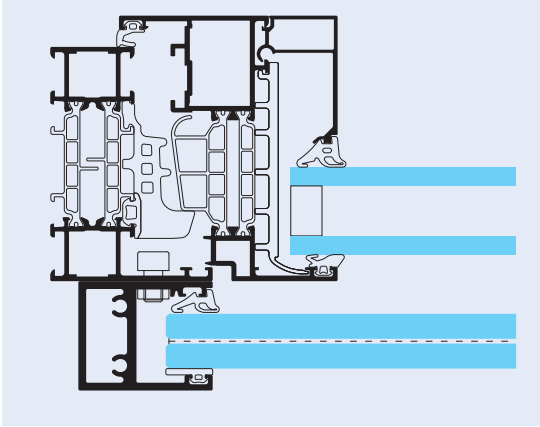

Soleal Next 75: Fixation from the inside

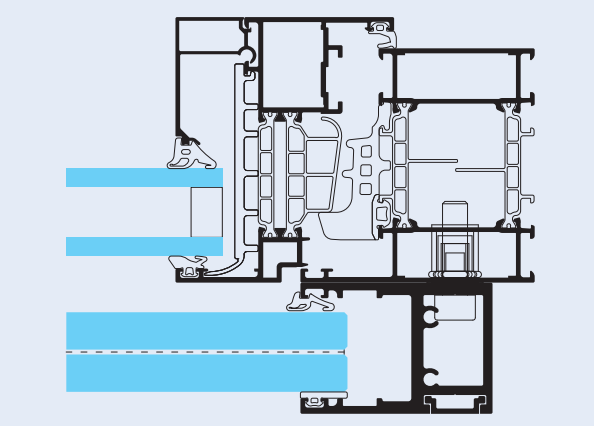

Soleal Next 75: fixation from the outside

# SOLEAL NEXT

/ MORE COMFORT

## MAGNETIC WINDOW CONTACT

The magnetic window contact is an additional security feature as it sends an alert on the user's device when the window is not properly closed.

- Easy to mount
- Integrated into the profile
- Certified for high-end security

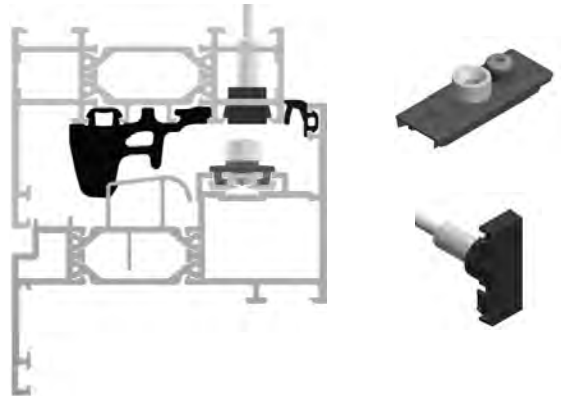

## WIRELESS WINDOW CONTACT

The wireless window detects the opening and closing state of the window.

- Easy to install and pair
- Suitable for building management system: for EnOcean
- Compatible with many home automation boxes, including Tahoma box from Somfy
- HVAC management
- Designed in recycled ABS
- Energy harvesting (no battery)

## MOTORISED OPENING CONTROL TO REDUCE ENERGY LOSS

Motorisation can be integrated in SOLEAL Next Minimal and Visible vent, tilt open-in, in both 65 and 75 modules.

- Simple solution, easy to install
- Concealed chain engine
- 1 or 2 chain drive depending on configuration
- High tightness performances: A4 - 900 Pa - C3
- Optional motorised window module available: provide feedback information, allows to control the motorisation in several ways and with other equipment
- Silent operation system; less than 35 dB
- Suitable for building management system : EnOcean and Modbus RTU
- 3 years guarantee



# SOLEAL NEXT

/ MORE SAFETY

## BURGLARY RESISTANCE

SOLEAL Next provides excellent protection against burglary, up to Resistance Class 3 (RC3) in accordance with EN-1627-30 and PAS24. It can be fitted with multi-point locks as an optional feature. Locking handles are available to increase security and reduce the risk of burglary.

## APPLICATIONS

RC3 available for the following window type:

- Visible 1 vent turn and turn & tilt

RC2 available for the following window types:

- Fixed frame
- Visible and Minimal 1 vent turn
- Visible and Minimal 1 vent turn & tilt

PAS 24 available for the following window types:

- Side hung 1 vent and 2 vents and top hung friction hinges open-out
- 1 vent turn & tilt open-in, Visible and Minimal vents





**Architect:** Anne Demians

**Photographer:** Jean Pierre PORCHER et Martin ARGYROGLO

# SOLEAL NEXT

/ MORE PERFORMANCES

Thanks to the property of our recycled aluminium, we are able to reduce the CO<sub>2</sub> footprint on stage A1 to A3 (raw material supply, transport and manufacturing).

SUSTAINABILITY PERFORMANCES [Results obtained with double glazing windows]					
Application	Dimensions L x H (mm)	Global Warming Potential /m <sup>2</sup> (kg CO2 eq. / m <sup>2</sup> )	Global Warming Potential element (kg CO2 eq. / m <sup>2</sup> )	Surface (m <sup>2</sup> )	Transparent area (m <sup>2</sup> )
SOLEAL Next 65 Visible	1000 x 1400	58.70	82.21	1.40	1.07
SOLEAL Next 65 Minimal	1000 x 1400	62.50	87.46	1.40	1.13
SOLEAL Next 75 Visible	1000 x 1400	53.90	75.50	1.40	1.07
SOLEAL Next 75 Minimal	1000 x 1400	58.70	82.20	1.40	1.13
SOLEAL Next 75 Open-out	1000 x 1400	57.80	80.87	1.40	1.03

Our modular design allows to cover several thermal performance levels, from hot temperature regions to the coldest parts of the world.

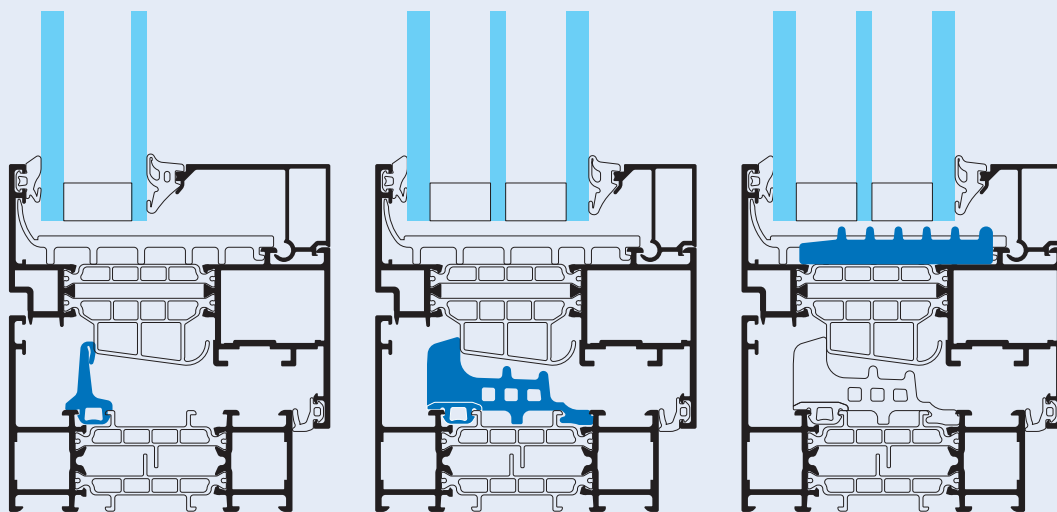

T-EFFICIENCY

T-PERFORMANCE

T-PERFORMANCE +

THERMAL PERFORMANCES - SOLEAL NEXT 65 (results obtained with «T-Performance +» version)								
Application	Dimensions W x H (mm)	U <sub>g</sub>	1.1	1.0	1.0	0.7	0.6	0.5
		spacer	Warm Edge Swisspacer Ultimate					
		glazing	24 mm	24 mm	28 mm	36 mm	42 mm	48 mm
<b>SOLEAL NEXT Visible Open-In 65 mm</b>								
window, 1 vent	1230 x 1480	U <sub>f moy</sub> =	1.9 W/m <sup>2</sup> .K					
		U <sub>w</sub> =	1.4	1.3	1.3	1.1	0.98	0.90
		S <sub>w</sub> =	0.54	0.54	0.54	0.49	0.49	0.49
		T <sub>Lw</sub> =	0.37	0.37	0.37	0.35	0.35	0.35
patio window, 1 vent	1230 x 2180	U <sub>f moy</sub> =	1.9 W/m <sup>2</sup> .K					
		U <sub>w</sub> =	1.3	1.3	1.3	1.0	0.93	0.85
		S <sub>w</sub> =	0.56	0.56	0.56	0.51	0.51	0.51
		T <sub>Lw</sub> =	0.39	0.39	0.39	0.36	0.36	0.36
window, 2 vents	1530 x 1480	U <sub>f moy</sub> =	1.9 W/m <sup>2</sup> .K					
		U <sub>w</sub> =	1.4	1.4	1.3	1.2	1.1	1.0
		S <sub>w</sub> =	0.49	0.49	0.49	0.45	0.45	0.45
		T <sub>Lw</sub> =	0.35	0.35	0.35	0.33	0.33	0.33
patio window, 2 vents	1530 x 2180	U <sub>f moy</sub> =	1.9 W/m <sup>2</sup> .K					
		U <sub>w</sub> =	1.4	1.3	1.3	1.1	1.0	0.96
		S <sub>w</sub> =	0.51	0.51	0.51	0.47	0.47	0.47
		T <sub>Lw</sub> =	0.36	0.36	0.36	0.34	0.34	0.34
<b>SOLEAL NEXT Minimal Open-In 65 mm</b>								
window, 1 vent	1230 x 1480	U <sub>f moy</sub> =	2.0 W/m <sup>2</sup> .K					
		U <sub>w</sub> =	1.4	1.3	1.3	1.0	0.96	-
		S <sub>w</sub> =	0.56	0.56	0.56	0.52	0.52	-
		T <sub>Lw</sub> =	0.39	0.39	0.39	0.37	0.37	-
patio window, 1 vent	1230 x 2180	U <sub>f moy</sub> =	2.0 W/m <sup>2</sup> .K					
		U <sub>w</sub> =	1.4	1.4	1.3	1.1	1.1	-
		S <sub>w</sub> =	0.53	0.53	0.53	0.48	0.48	-
		T <sub>Lw</sub> =	0.37	0.37	0.37	0.35	0.35	-

# SOLEAL NEXT

/ MORE PERFORMANCES

THERMAL PERFORMANCES - SOLEAL NEXT 75 (results obtained with «T-Performance +» version)								
Application	Dimensions L x H (mm)w	U <sub>g</sub>	1.1	1.0	1.0	0.7	0.6	0.5
		spacer	Warm Edge Swisspacer Ultimate					
		glazing	24 mm	24 mm	28 mm	36 mm	42 mm	48 mm
SOLEAL NEXT Visible Open-In 75 mm								
window, 1 vent	1230 x 1480	U <sub>f moy</sub> =	1.4 W/m <sup>2</sup> .K					
		U <sub>w</sub> =	1.3	1.2	1.2	0.96	0.87	0.79
		S <sub>w</sub> =	0.54	0.54	0.54	0.49	0.49	0.49
		T <sub>Lw</sub> =	0.37	0.37	0.37	0.35	0.35	0.35
patio window, 1 vent	1230 x 2180	U <sub>f moy</sub> =	1.4 W/m <sup>2</sup> .K					
		U <sub>w</sub> =	1.3	1.2	1.2	0.92	0.83	0.75
		S <sub>w</sub> =	0.56	0.56	0.56	0.51	0.51	0.51
		T <sub>Lw</sub> =	0.38	0.38	0.38	0.36	0.36	0.36
window, 2 vents	1530 x 1480	U <sub>f moy</sub> =	1.4 W/m <sup>2</sup> .K					
		U <sub>w</sub> =	1.3	1.3	1.2	1.0	0.94	0.86
		S <sub>w</sub> =	0.49	0.49	0.49	0.45	0.45	0.45
		T <sub>Lw</sub> =	0.34	0.34	0.34	0.32	0.32	0.32
patio window, 2 vents	1530 x 2180	U <sub>f moy</sub> =	1.4 W/m <sup>2</sup> .K					
		U <sub>w</sub> =	1.3	1.2	1.2	1.00	0.91	0.83
		S <sub>w</sub> =	0.51	0.51	0.51	0.47	0.47	0.47
		T <sub>Lw</sub> =	0.36	0.36	0.36	0.33	0.33	0.33
SOLEAL NEXT Visible Open-Out 75 mm								
window, 1 vent	1230 x 1480	U <sub>f moy</sub> =	1.5 W/m <sup>2</sup> .K					
		U <sub>w</sub> =	1.3	1.2	1.2	0.99	0.91	0.83
		S <sub>w</sub> =	0.52	0.52	0.52	0.47	0.47	0.47
		T <sub>Lw</sub> =	0.36	0.36	0.36	0.34	0.34	0.34
patio window, 1 vent	1230 x 2180	U <sub>f moy</sub> =	1.5 W/m <sup>2</sup> .K					
		U <sub>w</sub> =	1.3	1.2	1.2	0.96	0.87	0.79
		S <sub>w</sub> =	0.54	0.54	0.54	0.50	0.50	0.50
		T <sub>Lw</sub> =	0.37	0.37	0.37	0.35	0.35	0.35
window, 2 vents	1530 x 1480	U <sub>f moy</sub> =	1.5 W/m <sup>2</sup> .K					
		U <sub>w</sub> =	1.3	1.3	1.3	1.1	0.99	0.91
		S <sub>w</sub> =	0.47	0.47	0.47	0.43	0.43	0.43
		T <sub>Lw</sub> =	0.33	0.33	0.33	0.31	0.31	0.31

THERMAL PERFORMANCES - SOLEAL NEXT 75 (results obtained with «T-Performance +» version)								
Application	Dimensions L x H (mm)	U <sub>g</sub>	1.1	1.0	1.0	0.7	0.6	0.5
		spacer	Warm Edge Swisspacer Ultimate					
		glazing	24 mm	24 mm	28 mm	36 mm	42 mm	48 mm
<b>SOLEAL NEXT Minimal Open-In 75 mm</b>								
window, 1 vent	1230 x 1480	U <sub>f moy</sub> =	1.6 W/m <sup>2</sup> .K			1.5 W/m <sup>2</sup> .K		
		U <sub>w</sub> =	1.3	1.2	1.2	0.96	0.87	0.78
		S <sub>w</sub> =	0.56	0.56	0.56	0.52	0.52	0.52
		T <sub>Lw</sub> =	0.39	0.39	0.39	0.36	0.36	0.36
patio window, 1 vent	1230 x 2180	U <sub>f moy</sub> =	1.6 W/m <sup>2</sup> .K			1.5 W/m <sup>2</sup> .K		
		U <sub>w</sub> =	1.2	1.2	1.2	0.92	0.83	0.74
		S <sub>w</sub> =	0.58	0.58	0.58	0.53	0.53	0.53
		T <sub>Lw</sub> =	0.40	0.40	0.40	0.37	0.37	0.37
window, 2 vents	1530 x 1480	U <sub>f moy</sub> =	1.6 W/m <sup>2</sup> .K			1.5 W/m <sup>2</sup> .K		
		U <sub>w</sub> =	1.3	1.2	1.2	1.0	0.94	0.85
		S <sub>w</sub> =	0.53	0.53	0.53	0.48	0.48	0.48
		T <sub>Lw</sub> =	0.37	0.37	0.37	0.34	0.34	0.34
patio window, 2 vents	1530 x 2180	U <sub>f moy</sub> =	1.6 W/m <sup>2</sup> .K			1.5 W/m <sup>2</sup> .K		
		U <sub>w</sub> =	1.3	1.2	1.2	1.00	0.91	0.82
		S <sub>w</sub> =	0.55	0.55	0.55	0.50	0.50	0.50
		T <sub>Lw</sub> =	0.38	0.38	0.38	0.35	0.35	0.35

# SOLEAL NEXT

/ MORE PERFORMANCES

WEATHER PERFORMANCES - SOLEAL NEXT 65				
Application	W x H (mm)	Air tightness	Water tightness	Wind resistance
Visible Open-In, 1 vent turn&tilt	1394 x 3044	A4	1500	C5
Visible Open-In, 1 vent turn&tilt	1500 x 1700	A4	1500	C5
Visible Open-In, 1 vent turn&tilt	1500 x 2300	A4	1500	C5
Visible Open-in, 2 vents turn&tilt	2000 x 2300	A4	9A	C5
Minimal Open-In, 1 vent turn&tilt	1500 x 1700	A4	1050	C5
Minimal Open-In, 1 vent turn&tilt	1200 x 2300	A4	1050	C5
Minimal Open-In, 2 vent turn&tilt	1700 x 2300	A4	9A	C2
Motorization 1 chain drive, 1 vent tilt	1290 x 990	A4	9A	C3
Motorization 2 chain drives, 1 vent tilt	2490 x 890	A4	900	C3
Residential door Open-In 65 mm, 1 vent	1200 x 2300	A3	3A	C2

WEATHER PERFORMANCES - SOLEAL NEXT 75				
Application	W x H (mm)	Air tightness	Water tightness	Wind resistance
Visible Open-In, 1 vent turn&tilt	1500 x 1700	A4	1500	C5
Visible Open-In, 2 vents, turn&tilt	2000 x 2300	A4	9A	C2
Visible Open-Out, 1 vent side-hung	884 x 1844	A4	1500	C5
Visible Open-Out, 2 vents side-hung	1730 x 1844	A4	1350	C5
Visible Open-Out, top-hung, friction stay	1844 x 1844	A4	1800	C5
Minimal Open-In, 1 vent turn&tilt	1500 x 1700	A4	1050	C5
Motorization 1 chain drive, 1 vent tilt	1290 x 990	A4	9A	C3
Motorization 2 chain drives, 1 vent tilt	2490 x 890	A4	900	C3
Residential door open-out, 1 vent	1200 x 2300	A3	3A	C2

ACOUSTIC PERFORMANCES - SOLEAL NEXT 65							
L x H (mm)	Glazing composition	Glazing			Window		
		Rw	RA	RA,tr	Rw	RA	RA,tr
Visible, 1 vent turn&tilt							
1230 x 1480	4/16/6	36	35	31	36	34	31
	44.2/20/66.2	49	47	43	45	44	40
	88.2Ac/20/66.2Ac	52	51	47	47	46	44
Visible, 2 vents turn&tilt							
1450 x 2180	4/16/6	36	35	31	35	34	30
	44.2/20/66.2	49	47	43	45	44	40
	88.2Ac/20/66.2Ac	52	51	47	46	45	42
Minimal, 1 vent turn&tilt							
1230 x 1480	4/16/6	45	44	40	44	43	39
	44.2/20/66.2	36	35	31	35	34	32
	88.2Ac/20/66.2Ac	49	47	43	46	45	41

ACOUSTIC PERFORMANCES - SOLEAL NEXT 75							
L x H (mm)	Glazing composition	Glazing			Window		
		Rw	RA	RA,tr	Rw	RA	RA,tr
Visible, 1 vent turn&tilt							
1230 x 1480	4/16/6	36	35	31	36	34	31
	44.2/20/66.2	49	47	43	47	46	42
	88.2Ac/20/66.2Ac	52	51	47	48	47	45
Visible, Residential door							
1450 x 2180	4/16/6	36	35	31	35	33	30
	44.2/20/66.2	49	47	43	47	45	41
	88.2Ac/20/66.2Ac	52	51	47	47	45	42
Visible, 2 vents turn&tilt							
1230 x 1480	4/16/6	36	35	31	36	34	30
	10/16/66.2Ac	45	44	40	44	42	38
	44.2Ac/20/66.2Ac	49	47	43	46	44	40
Minimal, 1 vent turn&tilt							
1230 x 1480	10/16/66.2Ac	45	44	40	44	43	40
	66.2Ac/12/6/12/44.2Ac	49	47	43	47	46	42
	88.2Ac/20/66.2Ac	52	51	47	48	47	45

# SOLEAL NEXT

## / COMMITMENT AND SUSTAINABILITY

TECHNAL demonstrates its strong commitment to the environment in all areas: by using recycled and low-carbon materials, with a product design that is adapted to a circular economy, and produced within a responsible supply chain. In addition, these statements are certified by external organisations to ensure maximum transparency.

### HYDRO CIRCAL®

We are demonstrating our focus on sustainability by using Hydro CIRCAL® for our system solutions, one of the most sustainable aluminium alloys in our sector. Hydro CIRCAL® is a range of prime quality aluminium made with a minimum of 75% recycled end-of-life aluminium (post-consumer scrap). The production process is verified by an independent third party (DNV-GL), and confirmed by an EPD (Environmental Product Declaration). Hydro CIRCAL® also has **one of the smallest CO<sub>2</sub> footprint worldwide: 1.9 kg CO<sub>2</sub> per kilo of aluminium** – 4.5 times less than the world global primary average.

### RECYCLED & RECYCLABLE

Following our path to the certified circular economy, all of our systems are composed with a majority of materials and components that can be infinitely recyclable, that can come from recycled raw materials, that can be recycled to have a second life or components that can also be reused.

In rough figures, we're talking about **75% recycled content and 95% recyclable content**. It's an efficient way to drastically reduce the impact of materials on the life cycle of a building. Finally, our greener approach goes a step further thanks to recycled thermal strips for 75 mm modules.

**75% RECYCLED POST CONSUMER**

Hydro CIRCAL® is the world's first certified recycled aluminium which means that at least 75% of the prime-quality aluminium alloy comes from post-consumer materials.

**95% ENERGY SAVED**

By recycling post-consumer scrap aluminium, the remelting process saves up to 95% of energy that would normally be spent and maintain the same high quality as primary aluminium.

**85% REDUCTION OF CO<sub>2</sub> EMISSIONS**

The consequence of using Hydro CIRCAL® is the drastic reduction in CO<sub>2</sub> emissions which sums more than 85% when compared with the global average for primary aluminium production.



**SOLEAL NEXT**  
75% RECYCLED  
95% RECYCLABLE



# SOLEAL NEXT

## / CERTIFICATIONS



### CRADLE TO CRADLE (C2C) CERTIFICATION

From its design to the selection of materials and how it is manufactured, the product must offer the level of performance required by the market by reducing, to the greatest extent possible, environmental impacts such as energy consumption or greenhouse gas emissions.

We classify our range under the criteria of the Cradle to Cradle seal, an independent institute that certifies products and processes from a circular economy perspective. We have numerous Cradle to Cradle certified series, including the manufacturing in our plants. In this way, we are able to ensure that the carbon footprint of transporting our products is as low as possible.

**Our range is under certification.**



### ALUMINIUM STEWARD INITIATIVE (ASI)

ASI is a multi-stakeholder, non-profit, standards-setting and certification organisation. It is the most internationally recognised standard, which addresses the environmental, social and governance (ESG) aspects of the entire aluminium value chain. The assessment is based around the sustainable production of aluminium, from bauxite or mining to the production of semi-fabricated products, taking into account the recycling of pre- and post-consumer scrap. Hydro was one of the first companies, that received this recognition, in accordance with its commitment to a more sustainable future.

**100% of our extrusion plants are ASI Performance Standard Certified.**



### ENVIRONMENTAL PRODUCT DECLARATION

An Environmental Product Declaration (EPD) is an independently third party-verified document that communicates precise, transparent and comparable information about the life-cycle environmental impacts of a product. But it is not only limited to products, such as a window, but can also be applied to materials (an aluminium billet), assembly parts of products or even for services (like maintenance). This document is used for many different applications, e.g. public procurement or green building rating schemes (i.e. BREEAM, LEED, DGNB).

**Thanks to our software TechDesign, it's possible to generate a dynamic EPD according specified dimensions, applications any type of glazing.**



**Architect:** OECO Architectes  
**Photographer:** Kevin Dolmaire



IMAGINE WHAT'S NEXT

270, rue Léon-Joulin  
BP 63709 - 31037 Toulouse cedex 1  
Tél. 05 61 31 28 28 - [www.technal.com](http://www.technal.com)

